

KEY FEATURES

- Dual Channel | 2x Up / Down Channels
- Bi-Directional RF / IF
- LO 8-32 GHz 1MHz Step
- Frequency and Phase Locked
- Variable RF and IF Gain Control
- Spur Filtering and Control
- Internal / External Frequency Reference (10, 100, 200MHz + Custom)



APPLICATIONS

- RF Automated Testing
- VNA Test Equipment Extender
- Low-cost Ka Band Antenna Measurement
- 5G & 6G Phased Arrays
- Low-cost Production Test Stations

PRODUCT DESCRIPTION

EECL is pleased to offer the market a dual channel converter module that can be configured for RF->IF or IF->RF (independent) conversion utilising two frequency and phase locked channels. Gain control of 48dB on RF and 32dB on IF with a maximum gain of 25dB. Up and Down conversion can be reversed as required independently.

Each channel has an extremely high isolation of 90dB. The LO used for mixing is generated from an extremely low phase noise VCO and can be set anywhere from 8GHz to 32GHz. The unit has integrated tuneable harmonic filters to prevent unwanted spurious, and the unit provides extremely high dynamic range and low noise figure.

Unwanted sidebands can be removed as required. The unit takes up to a 48V power supply and operates over USB with a simple UART based command set, perfect to control with Matlab, C, and Labview. The unit is drift stabilised by the inclusion of an oven and therefore suitable for long term use in a calibrated system.

TYPICAL PERFORMANCE DATA - DCX-23202

The following plots show a modulated signal of 125MHz bandwidth being upconverted. The EVM is measured and it can be seen that the total distortion of the chain is extremely pure.

It can be seen that the converter can convert a signal at 14GHz, 19GHz, 12.5GHz and 30GHz with EVM of 41.2dB, 35dB, 30dB and 31dB respectively.

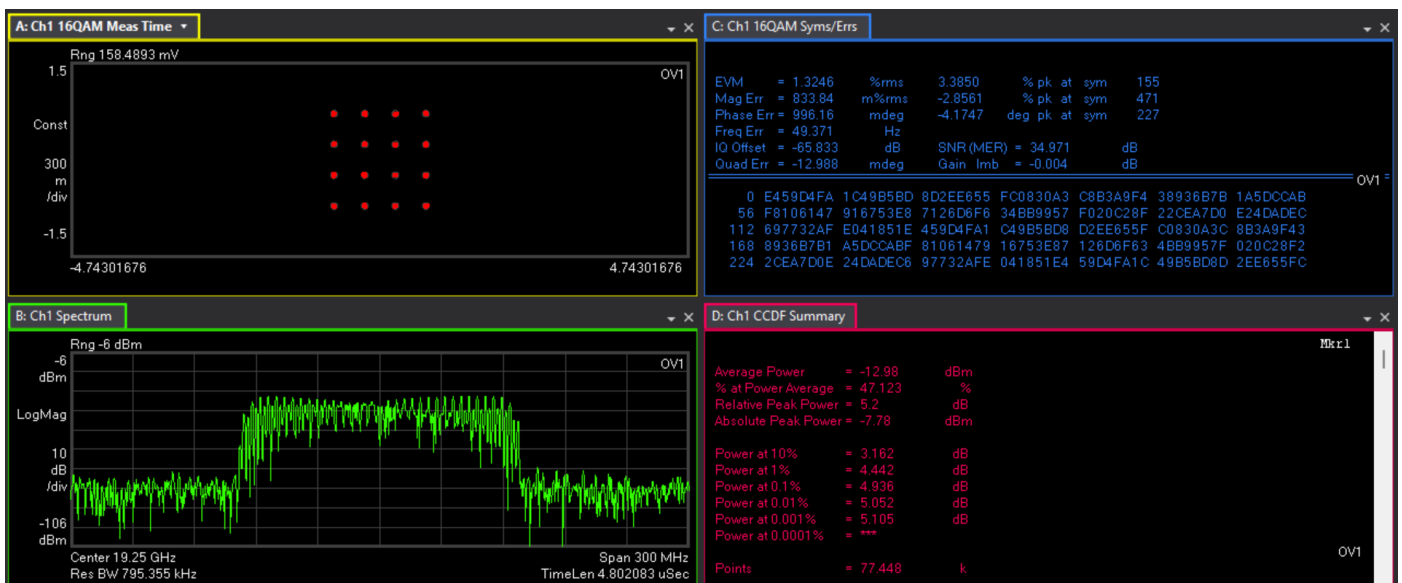
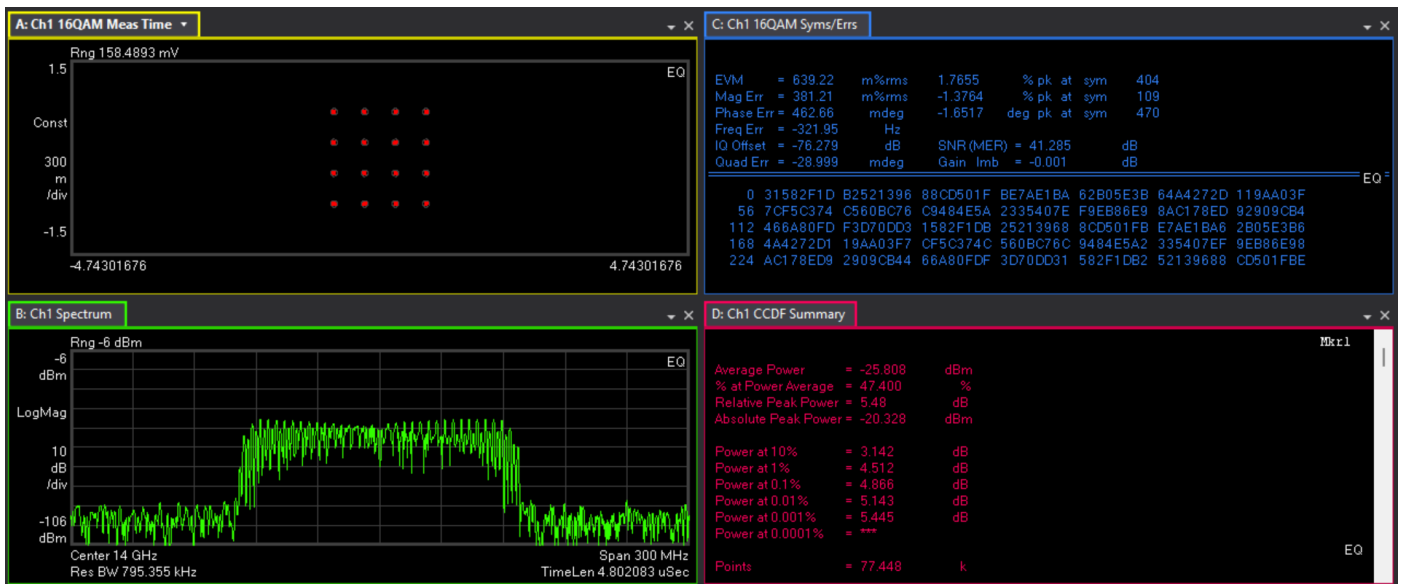

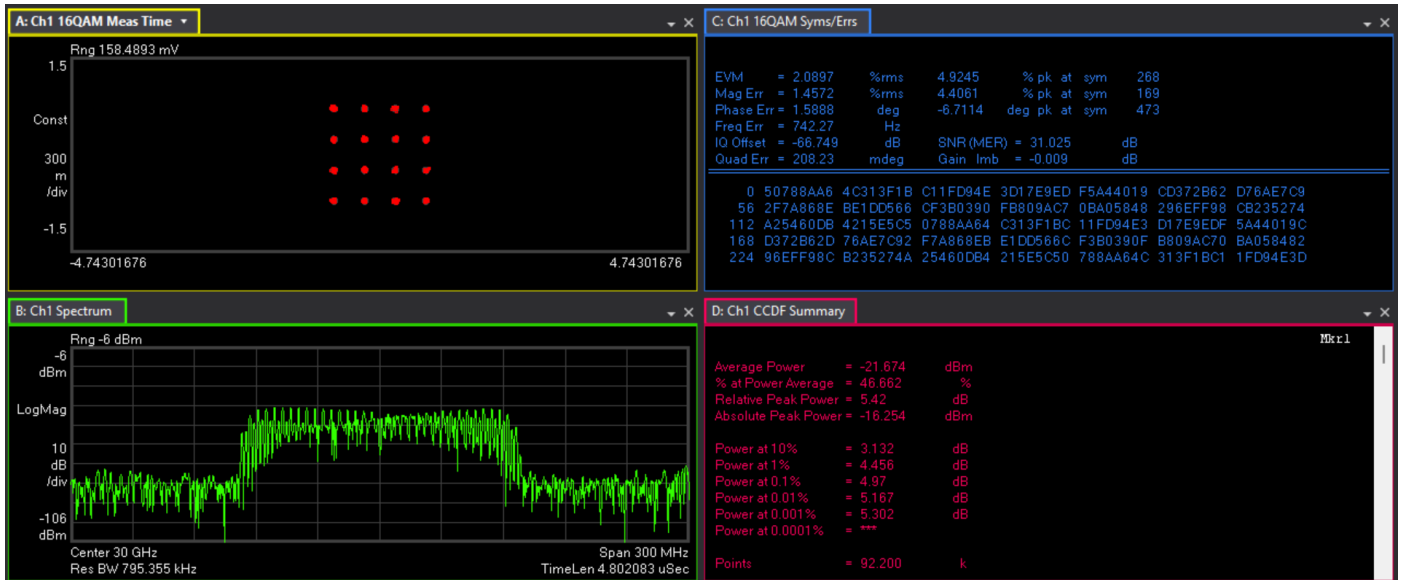
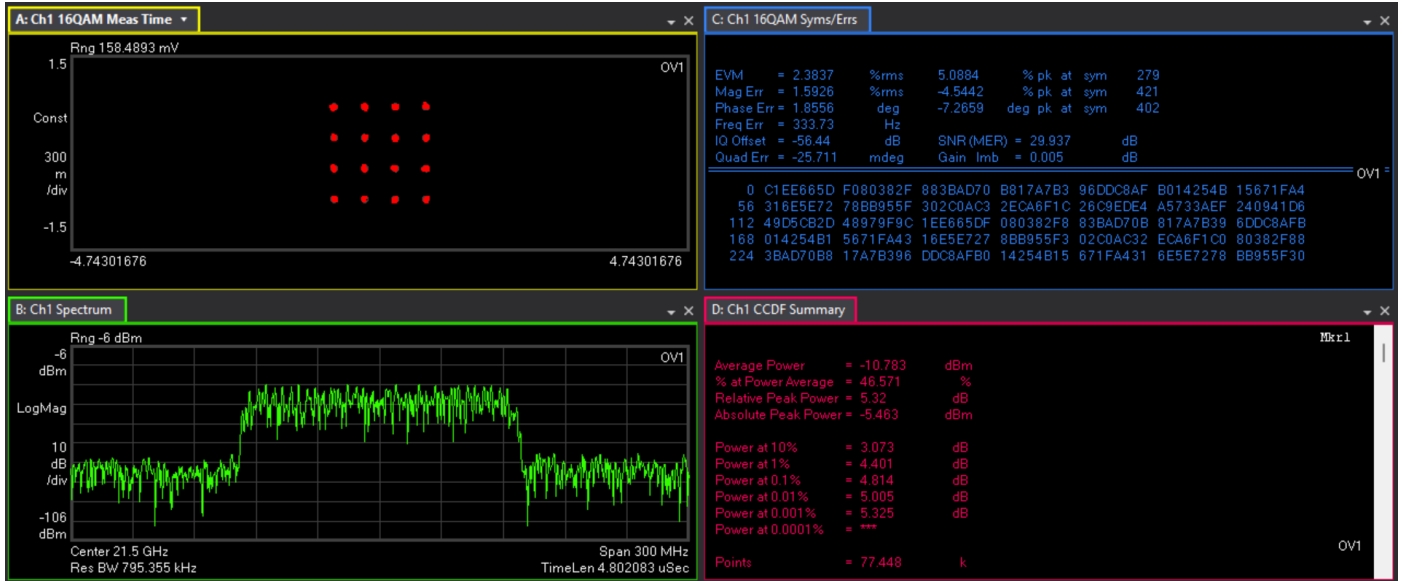

Typical conversion gain curves, spectrum plots and attenuator settings are shown below:

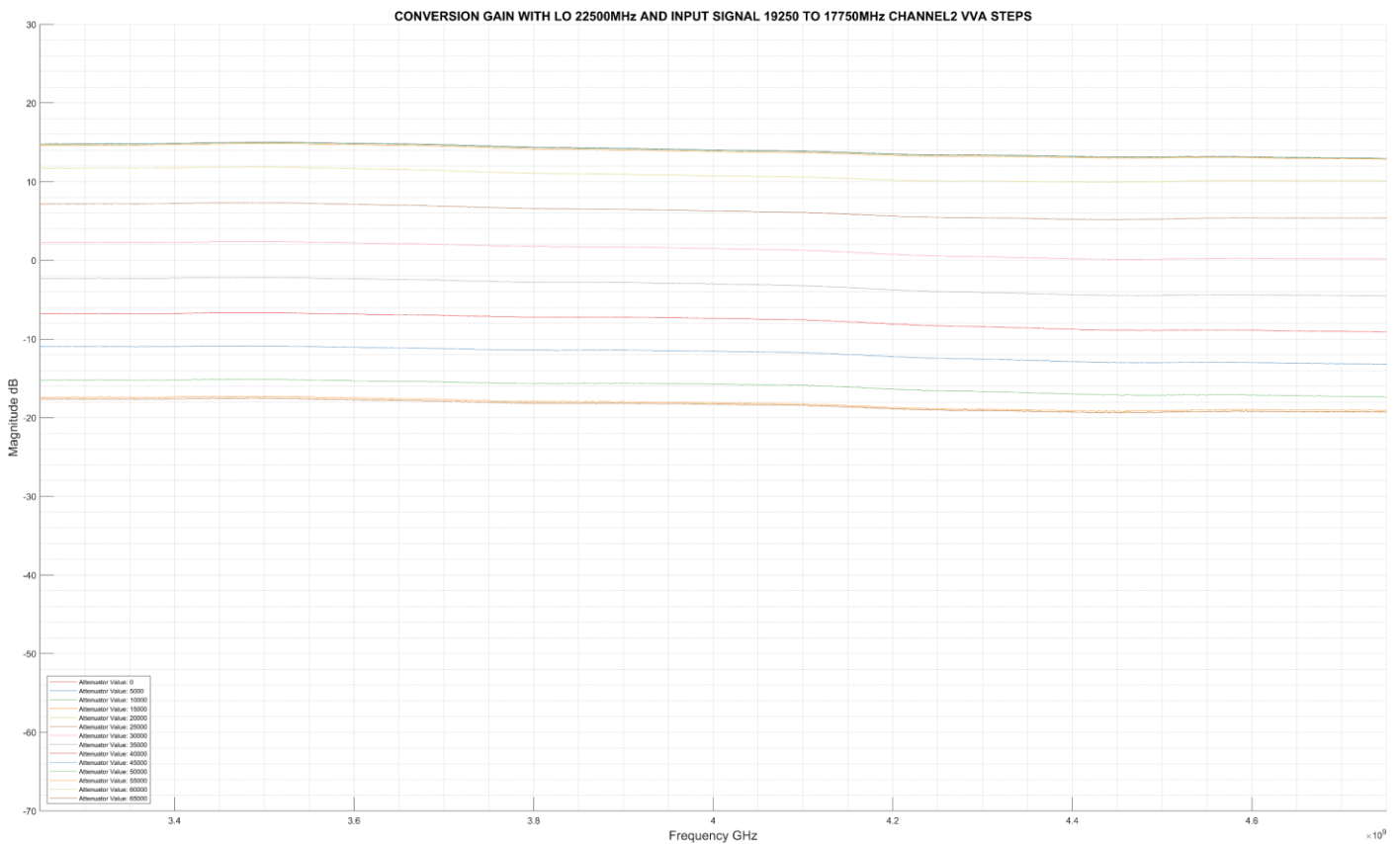
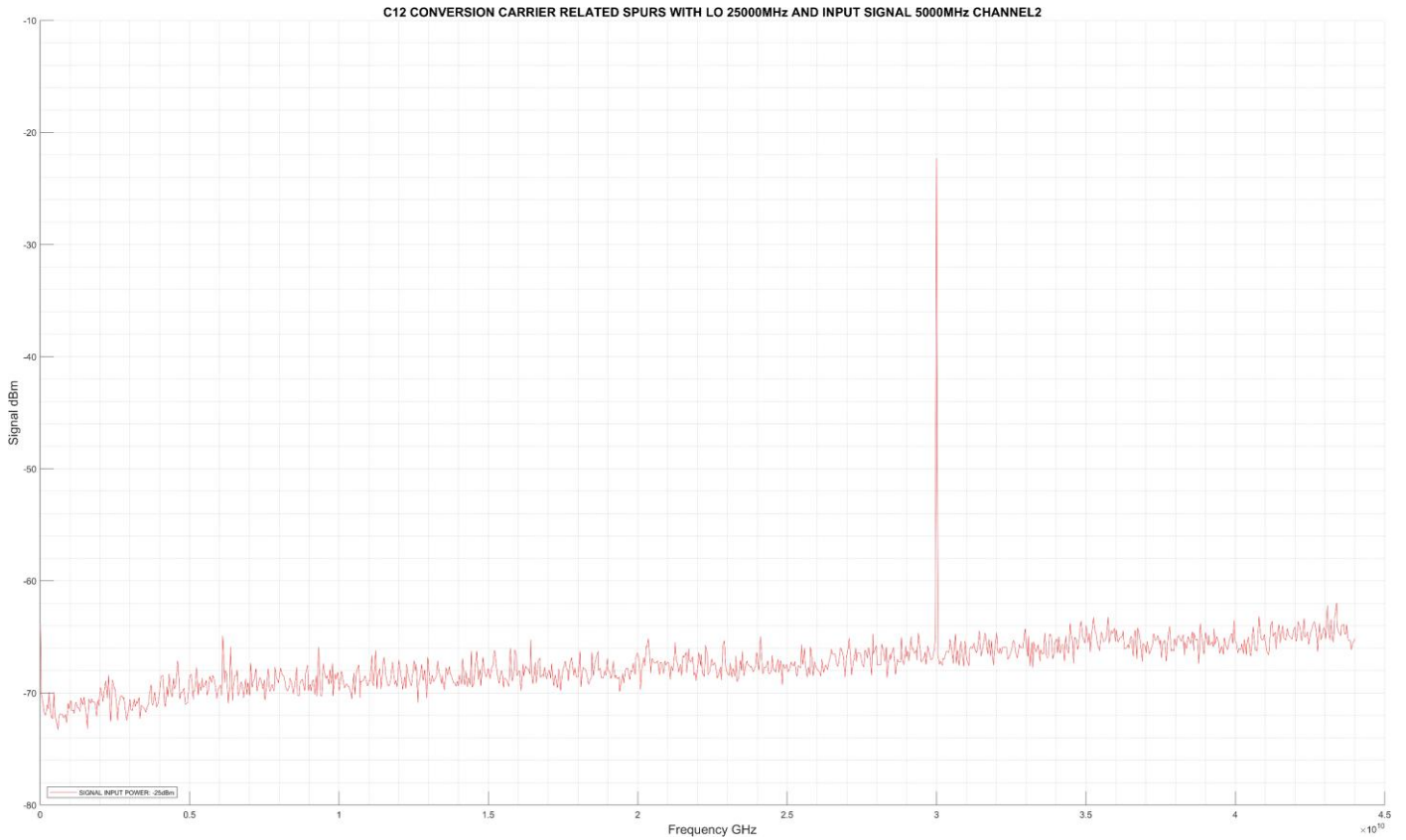

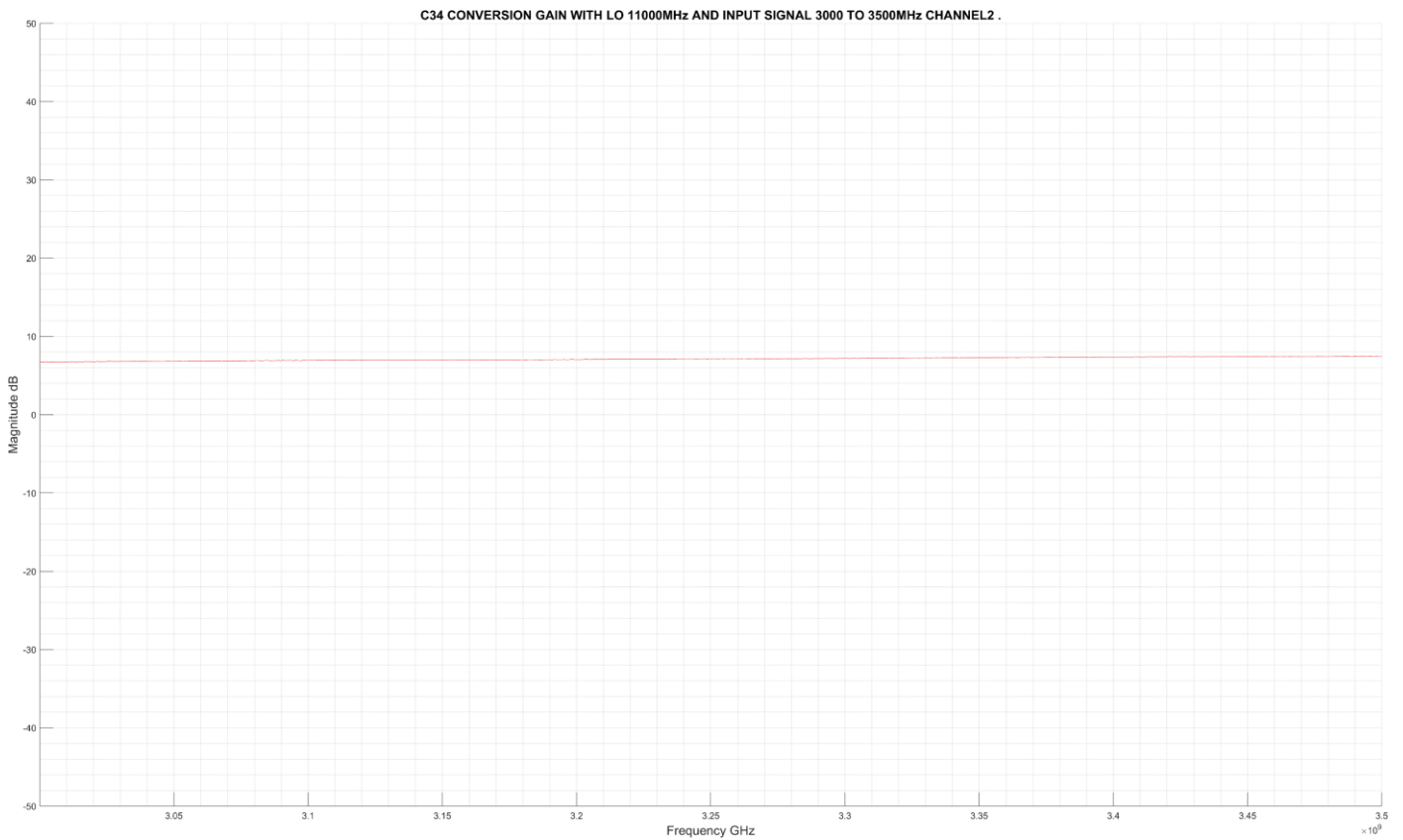
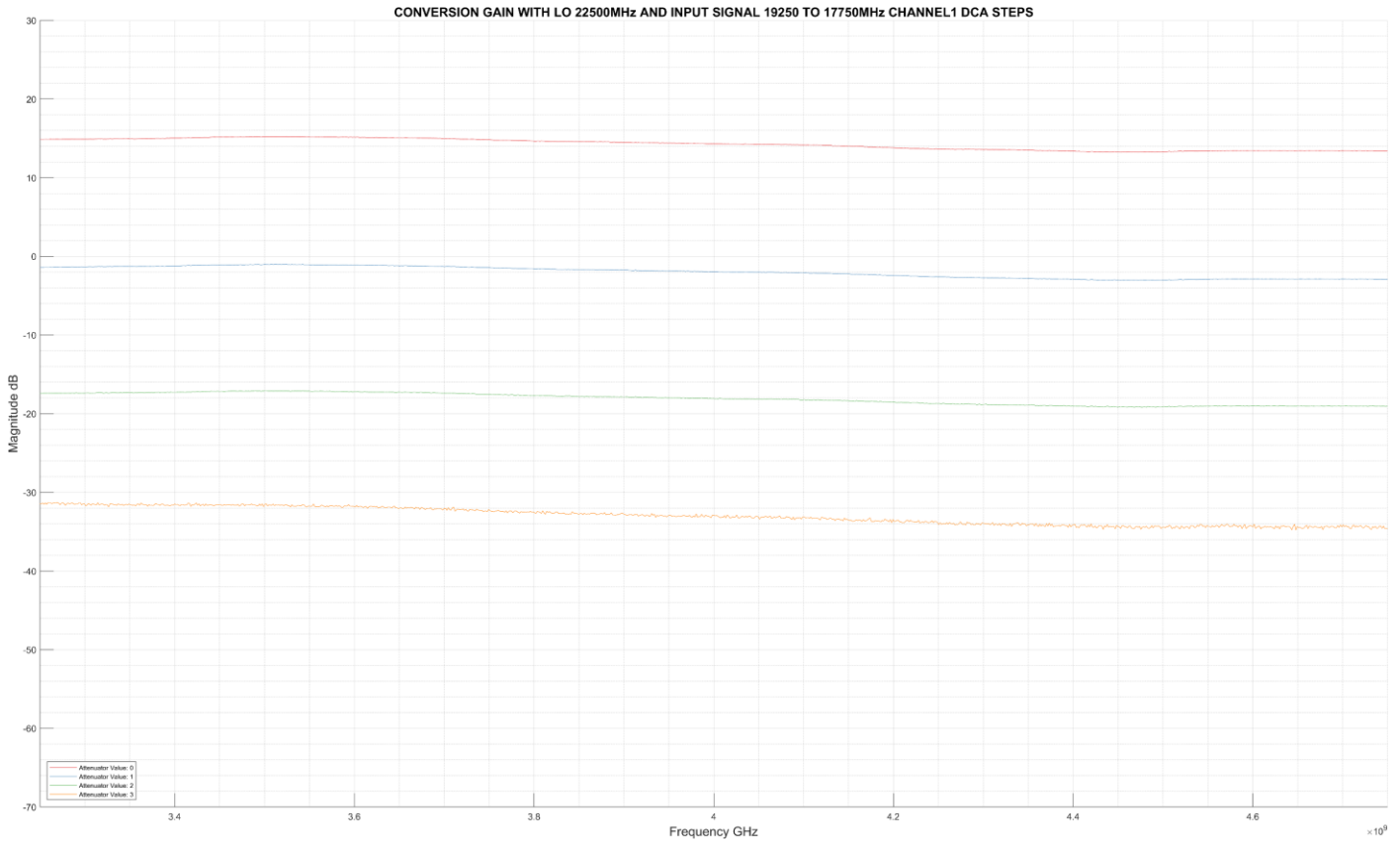

FUNCTIONAL BLOCK DIAGRAM

A simplified (equivalent) system block diagram of the converter is shown below.

The two branches are identical and are fed by a single LO. This ensures we get correlated gain and phase. Each arm has a switched filter bank to remove unwanted sidebands and LO leakage. There is gain on the RF path for output and input (reversible) but only gain on the IF path for output. This is because the intended use of the converter is to come from known stronger lab equipment and therefore IF input gain is not required.

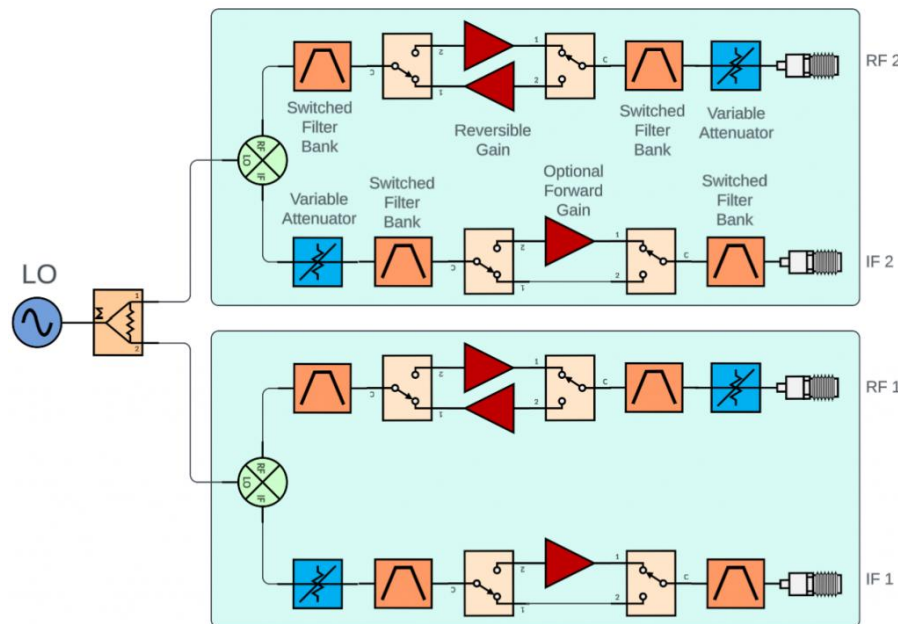

The attenuators provide up to 60dB of attenuation range. At minimum settings the overall conversion gain is around 5dB positive depending on the particular band being operated. The RF ports are capable of around +3 dBm output power.

The RF port has a 0, 16, 32 or 48dB selectable attenuator and it is capable of handling high input powers up to 26dBm whilst maintaining linearity. For up convert the IF port the input power should be set between -30dBm and 0dBm for maximum SNR on the RF port.

FREQUENCY PLAN

The Local Oscillator (LO) is highly versatile, supporting a range from **8 GHz to 32 GHz** with a **1 MHz step resolution**. The system supports both up-conversion and down-conversion across the following frequency ranges:

- **RF Range:** 8 GHz to 32 GHz
- **IF Range:** DC to 8 GHz

While the system supports any mathematical combination of these frequencies, we recommend using the configurations provided in the table below to ensure **optimal performance** and maximum **spur/image suppression**.

Note: The table below highlights several optimized configurations, but it is not an exhaustive list. The system supports a virtually infinite number of frequency combinations. For unique frequency plans, we can also customize the image rejection filters upon request to ensure peak performance.

IF	LO	RF Lower	RF Upper
5.5	13.5	8	19
4.5	13.5	9	18
3.5	13.5	10	17
2.5	13.5	11	16
4.5	15.5	11	20
3.5	15.5	12	19
2.5	15.5	13	18
1.5	15.5	14	17
3	11	8	14
3.5	11	7.5	14.5
4.5	11	6.5	15.5
6.5	11	4.5	17.5
7	24.5	17.5	31.5
6.5	24.5	18	31
5.5	24.5	19	30
4.5	24.5	20	29
3.5	24.5	21	29
3	24.5	21.5	27.5
2.5	19	16.5	21.5
3.5	19	15.5	22.5
4.5	19	14.5	23.5
5.5	19	13.5	24.5
6	19	13	25
2	22.5	20.5	24.5
3	22.5	19.5	25.5
4	22.5	18.5	26.5
5	22.5	17.5	27.5
6	22.5	16.5	28.5
8	22.5	14.5	30.5

USE AS VNA EXTENDER

The converter can be used as a VNA frequency extender (for S_{21} measurements) in applications such as antenna anechoic chamber measurements.

This allows an extremely low-cost measurement system to be used with practically identical measurement quality. The plot below shows our Dual Converter with a Low-Cost Low-Frequency VNA, compared to a High-Cost Keysight VNA. For more information on this VNA frequency extension technique, please consult EECL Application Note AN2501, available here: <https://eecl.co.uk/wp-content/uploads/2026/02/AN2501-Vector-S21-Measurement-with-EECL-Dual-Frequency-Extender.pdf>

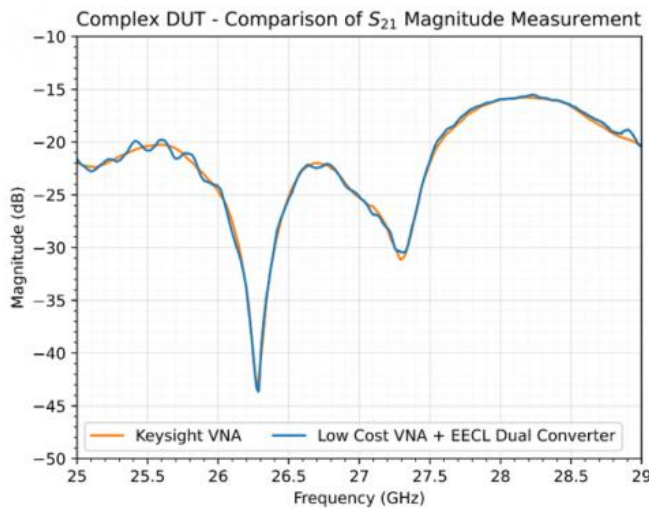

(a) S_{21} magnitude (dB)

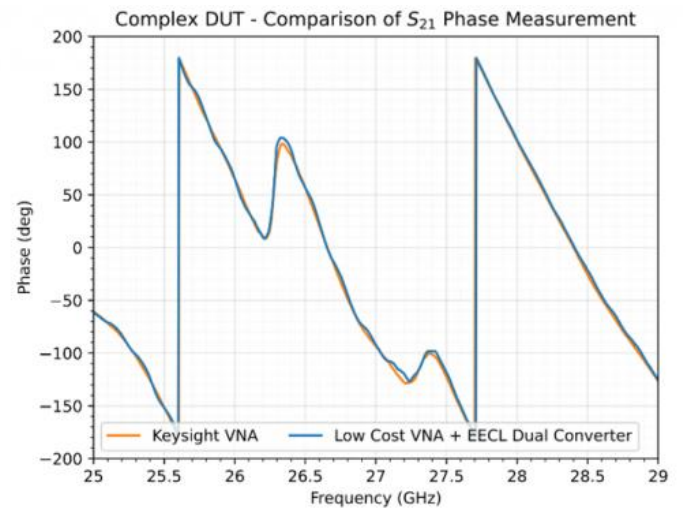

(b) S_{21} phase (deg)

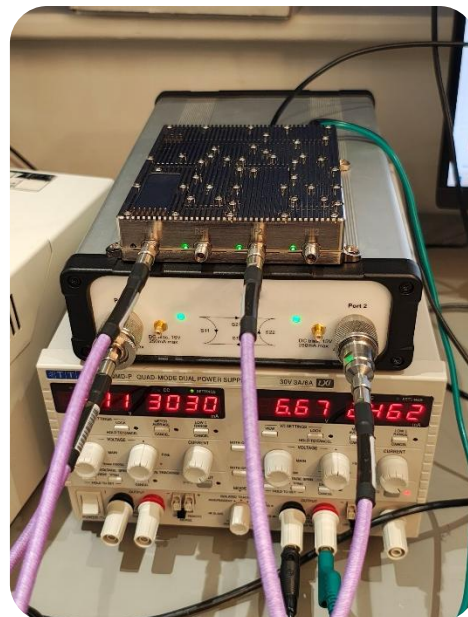

MECHANICAL INFORMATION

Dimensions are in mm.

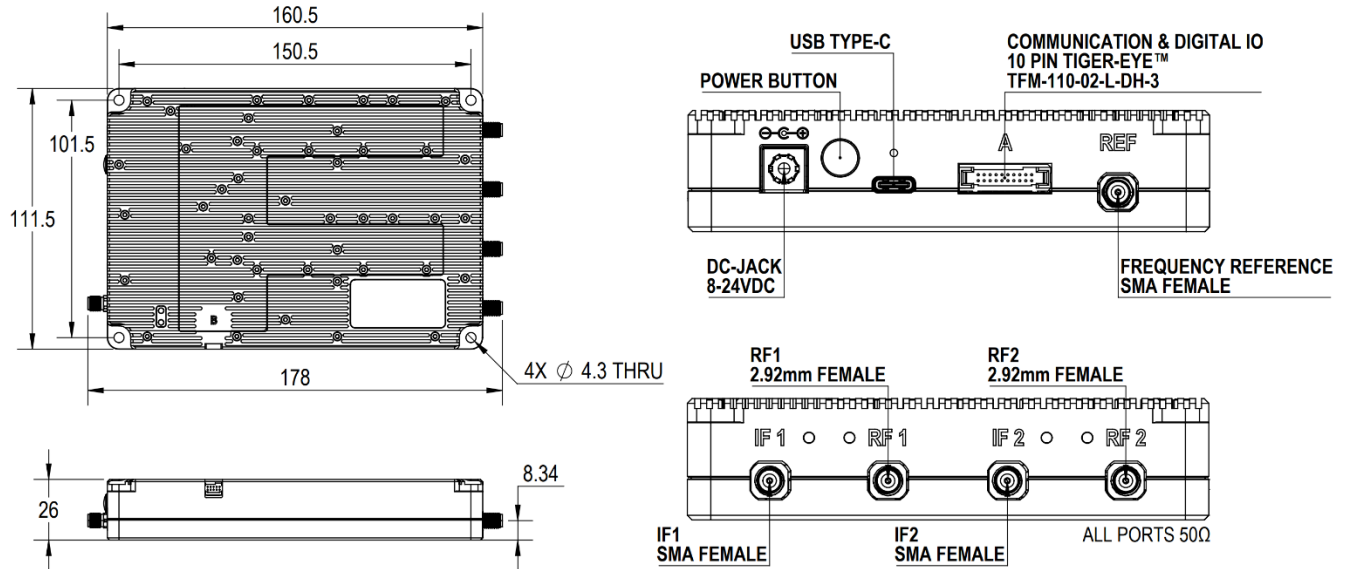

SPECIFICATIONS

	DCX-23202
IF Frequency	16KHz – 8GHz
RF Frequency	8GHz – 32GHz
Synthesizer Frequency	8GHz – 32GHz
Gain Control	80 dB
Output Power Max	+ 3 dBm
Trigger	TTL 3V3
Control Interfaces	USB 2.0 (USB C)
Operating Temperature	0 °C to +40 °C
Operating Humidity	95% RH at 40 °C (non-condensing)
Port Type	SMA Female for IF , 2.92mm Female for RF
Power Supply	DC Jack – 8-24V DC
Average Power Consumption	8W